

## TS3A474x 0.9-Ω Low-Voltage Single-Supply 2-Channel SPST Analog Switches

### 1 Features

- Low ON-State Resistance ( $R_{on}$ )
  - 0.9-Ω Max (3-V Supply)
  - 1.5-Ω Max (1.8-V Supply)
- 0.4-Ω Max  $R_{on}$  Flatness (3-V Supply)
- 1.6-V to 3.6-V Single-Supply Operation
- Available in SOT-23 and VSSOP Packages
- High Current-Handling Capacity (100 mA Continuous)
- 1.8-V CMOS Logic Compatible (3-V Supply)
- Fast Switching:  $t_{ON} = 14$  ns,  $t_{OFF} = 9$  ns

### 2 Applications

- Power Routing
- Battery-Powered Systems
- Audio and Video Signal Routing
- Low-Voltage Data-Acquisition Systems
- Communications Circuits
- PCMCIA Cards
- Cellular Phones
- Modems
- Hard Drives

### 3 Description

The TS3A4741 and TS3A4742 are bi-directional, 2-channel single-pole/single-throw (SPST) analog switches with low ON-state resistance ( $R_{on}$ ), low-voltage, that operate from a single 1.6-V to 3.6-V supply. These devices have fast switching speeds, handle rail-to-rail analog signals, and consume very low quiescent power.

The digital logic input is 1.8-V CMOS compatible when using a single 3-V supply.

The TS3A4741 has two normally open (NO) switches, and the TS3A4742 has two normally closed (NC) switches.

#### Device Information<sup>(1)</sup>

PART NUMBER	PACKAGE	BODY SIZE (NOM)
TS3A4741	SOT (8)	2.90 mm × 1.63 mm
	VSSOP (8)	3.00 mm × 3.00 mm
TS3A4742	SOT (8)	2.90 mm × 1.63 mm
	VSSOP (8)	3.00 mm × 3.00 mm

(1) For all available packages, see the orderable addendum at the end of the datasheet.

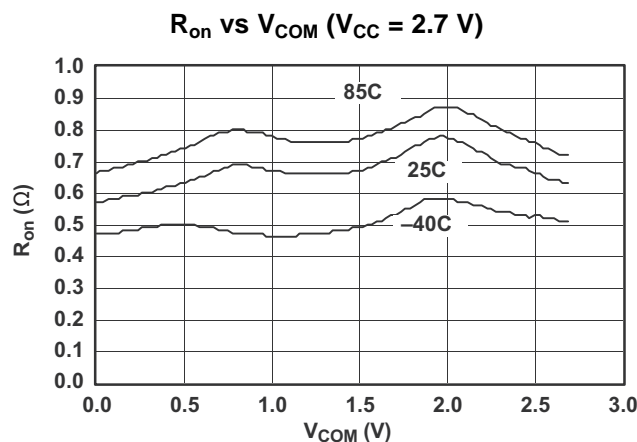

## Table of Contents

<b>1 Features</b> ..... 1 <b>2 Applications</b> ..... 1 <b>3 Description</b> ..... 1 <b>4 Revision History</b> ..... 2 <b>5 Pin Configuration and Functions</b> ..... 3 <b>6 Specifications</b> ..... 4 6.1 Absolute Maximum Ratings ..... 4 6.2 ESD Ratings ..... 4 6.3 Recommended Operating Conditions ..... 4 6.4 Thermal Information ..... 4 6.5 Electrical Characteristics (3-V Supply) ..... 5 6.6 Electrical Characteristics (1.8-V Supply) ..... 7 6.7 Typical Characteristics ..... 8 <b>7 Parameter Measurement Information</b> ..... 11 <b>8 Detailed Description</b> ..... 14 8.1 Overview ..... 14	8.2 Functional Block Diagram ..... 14 8.3 Feature Description ..... 14 8.4 Device Functional Modes ..... 14 <b>9 Application and Implementation</b> ..... 15 9.1 Application Information ..... 15 9.2 Typical Application ..... 15 <b>10 Power Supply Recommendations</b> ..... 17 <b>11 Layout</b> ..... 17 11.1 Layout Guidelines ..... 17 11.2 Layout Example ..... 17 <b>12 Device and Documentation Support</b> ..... 18 12.1 Related Links ..... 18 12.2 Trademarks ..... 18 12.3 Electrostatic Discharge Caution ..... 18 12.4 Glossary ..... 18 <b>13 Mechanical, Packaging, and Orderable Information</b> ..... 18
---	--

## 4 Revision History

### Changes from Revision D (June 2014) to Revision E

**Page**

- Added *Pin Configuration and Functions* section, *ESD Ratings* table, *Feature Description* section, *Device Functional Modes*, *Application and Implementation* section, *Power Supply Recommendations* section, *Layout* section, *Device and Documentation Support* section, and *Mechanical, Packaging, and Orderable Information* section ..... 1

## 5 Pin Configuration and Functions

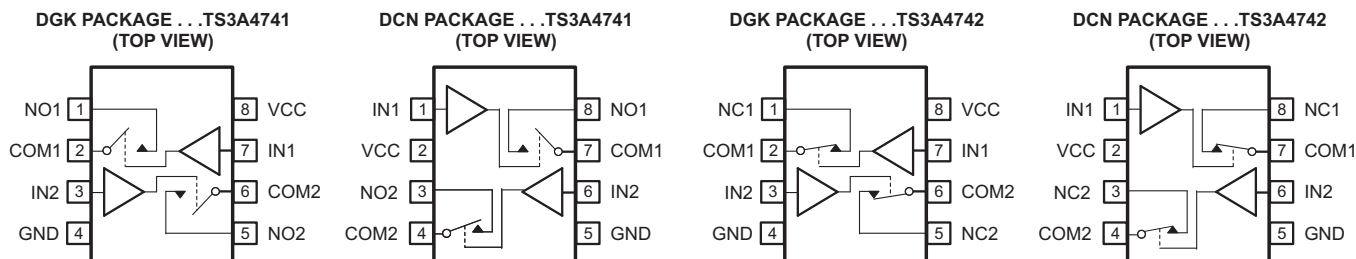

### Pin Functions

NAME	PIN				I/O	DESCRIPTION
	TS3A4741		TS3A4742			
	MSOP	SOT	MSOP	SOT		
COM1	2	7	2	7	I/O	Common
COM2	6	4	6	4	I/O	Common
GND	4	5	4	5	—	Ground
IN1	7	1	7	1	I	Digital control to connect COM to NO or NC
IN2	3	6	3	6	I	Digital control to connect COM to NO or NC
NC1	—	—	1	8	I/O	Normally closed
NC2	—	—	5	3	I/O	Normally closed
NO1	1	8	—	—	I/O	Normally open
NO2	5	3	—	—	I/O	Normally open
VCC	8	2	8	2	I	Power supply

## 6 Specifications

### 6.1 Absolute Maximum Ratings<sup>(1)</sup>

over operating free-air temperature range (unless otherwise noted)

		MIN	MAX	UNIT
$V_{CC}$	Supply voltage reference to GND <sup>(2)</sup>	-0.3	4	V
$V_{NO}$ $V_{COM}$ $V_{IN}$	Analog and digital voltage	-0.3	$V_{CC} + 0.3$	
$I_{NO}$ $I_{COM}$	On-state switch current	$V_{NO}, V_{COM} = 0$ to $V_{CC}$		mA
$I_{CC}$ $I_{GND}$	Continuous current through $V_{CC}$ or GND			
	Peak current pulsed at 1 ms, 10% duty cycle	COM, $V_{NO}, V_{COM}$		
$T_A$	Operating temperature	-40	85	°C
$T_J$	Junction temperature		150	
$T_{stg}$	Storage temperature	-65	150	

- (1) Stresses beyond those listed under Absolute Maximum Ratings may cause permanent damage to the device. These are stress ratings only, and functional operation of the device at these or any other conditions beyond those indicated under *Recommended Operating Conditions* is not implied. Exposure to absolute-maximum-rated conditions for extended periods may affect device reliability.
- (2) Signals on COM or NO exceeding  $V_{CC}$  or GND are clamped by internal diodes. Limit forward diode current to maximum current rating.

### 6.2 ESD Ratings

		VALUE	UNIT
$V_{(ESD)}$	Electrostatic discharge	Human-body model (HBM), per ANSI/ESDA/JEDEC JS-001 <sup>(1)</sup>	±4000
		Charged-device model (CDM), per JEDEC specification JESD22-C101 <sup>(2)</sup>	±1000

- (1) JEDEC document JEP155 states that 500-V HBM allows safe manufacturing with a standard ESD control process.
- (2) JEDEC document JEP157 states that 250-V CDM allows safe manufacturing with a standard ESD control process.

### 6.3 Recommended Operating Conditions

over operating free-air temperature range (unless otherwise noted)

		MIN	MAX	UNIT
$V_{CC}$	Supply voltage reference to ground	1.6	3.6	V
$V_{NO}$ $V_{COM}$	Analog voltage	0	3.6	
$V_{IN}$	Digital Voltage	0	1.8	

### 6.4 Thermal Information

THERMAL METRIC <sup>(1)</sup>		TS3A474x	UNIT
		DCN/DGK	
		8 PINS	
$R_{\theta JA}$	Junction-to-ambient thermal resistance	214.8	°C/W
$R_{\theta JC(top)}$	Junction-to-case (top) thermal resistance	191.0	
$R_{\theta JB}$	Junction-to-board thermal resistance	113.1	
$\Psi_{JT}$	Junction-to-top characterization parameter	52.4	
$\Psi_{JB}$	Junction-to-board characterization parameter	110.2	

- (1) For more information about traditional and new thermal metrics, see the *IC Package Thermal Metrics* application report, [SPRA953](#).

## 6.5 Electrical Characteristics (3-V Supply)<sup>(1)(2)</sup>

 $V_{CC} = 2.7\text{ V to }3.6\text{ V}$ ,  $T_A = -40\text{ to }85^\circ\text{C}$ ,  $V_{IH} = 1.4\text{ V}$ ,  $V_{IL} = 0.5\text{ V}$  (unless otherwise noted)

PARAMETER		TEST CONDITIONS	$T_A$	MIN	TYP <sup>(3)</sup>	MAX	UNIT
<b>ANALOG SWITCH</b>							
$V_{COM}, V_{NO}, V_{NC}$	Analog signal range			0		$V_+$	V
$R_{on}$	ON-state resistance	$V_{CC} = 2.7\text{ V}$ , $I_{COM} = -100\text{ mA}$ , $V_{NO}, V_{NC} = 1.5\text{ V}$	25°C		0.7	0.9	$\Omega$
			Full			1.1	
$\Delta R_{on}$	ON-state resistance match between channels <sup>(4)</sup>	$V_{CC} = 2.7\text{ V}$ , $I_{COM} = -100\text{ mA}$ , $V_{NO}, V_{NC} = 1.5\text{ V}$	25°C		0.03	0.05	$\Omega$
			Full			0.15	
$R_{on(Flat)}$	ON-state resistance flatness <sup>(5)</sup>	$V_{CC} = 2.7\text{ V}$ , $I_{COM} = -100\text{ mA}$ , $V_{NO}, V_{NC} = 1\text{ V}, 1.5\text{ V}, 2\text{ V}$	25°C		0.23	0.4	$\Omega$
			Full			0.5	
$I_{NO(OFF)}$	NO OFF leakage current <sup>(6)</sup>	$V_{CC} = 3.6\text{ V}$ , $V_{COM} = 0.3\text{ V}, 3\text{ V}$ , $V_{NO} = 3\text{ V}, 0.3\text{ V}$	25°C	-2	1	2	nA
			Full	-18		18	
$I_{COM(OFF)}$	COM OFF leakage current <sup>(6)</sup>	$V_{CC} = 3.6\text{ V}$ , $V_{COM} = 0.3\text{ V}, 3\text{ V}$ , $V_{NO} = 3\text{ V}, 0.3\text{ V}$	25°C	-2	1	2	nA
			Full	-18		18	
$I_{COM(ON)}$	COM ON leakage current <sup>(6)</sup>	$V_{CC} = 3.6\text{ V}$ , $V_{COM} = 0.3\text{ V}, 3\text{ V}$ , $V_{NO} = 0.3\text{ V}, 3\text{ V}$ , or floating	25°C	-2.5	0.01	2.5	nA
			Full	-5		5	
<b>DYNAMIC</b>							
$t_{ON}$	Turn-on time	$V_{NO}, V_{NC} = 1.5\text{ V}$ , $R_L = 50\ \Omega$ , $C_L = 35\text{ pF}$ , See <a href="#">Figure 14</a>	25°C		5	14	ns
			Full			15	
$t_{OFF}$	Turn-off time	$V_{NO}, V_{NC} = 1.5\text{ V}$ , $R_L = 50\ \Omega$ , $C_L = 35\text{ pF}$ , See <a href="#">Figure 14</a>	25°C		4	9	ns
			Full			10	
$Q_C$	Charge injection	$V_{GEN} = 0$ , $R_{GEN} = 0$ , $C_L = 1\text{ nF}$ , See <a href="#">Figure 15</a>	25°C		3		pC
$C_{NO(OFF)}$	NO OFF capacitance	$f = 1\text{ MHz}$ , See <a href="#">Figure 16</a>	25°C		23		pF
$C_{COM(OFF)}$	COM OFF capacitance	$f = 1\text{ MHz}$ , See <a href="#">Figure 16</a>	25°C		20		
$C_{COM(ON)}$	COM ON capacitance	$f = 1\text{ MHz}$ , See <a href="#">Figure 16</a>	25°C		43		
$BW$	Bandwidth	$R_L = 50\ \Omega$ , Switch ON	25°C		125		MHz
$O_{ISO}$	OFF isolation <sup>(7)</sup>	$R_L = 50\ \Omega$ , $C_L = 5\text{ pF}$ , See <a href="#">Figure 17</a>	25°C		$f = 10\text{ MHz}$	-40	dB
					$f = 1\text{ MHz}$	-62	
$X_{TALK}$	Crosstalk	$R_L = 50\ \Omega$ , $C_L = 5\text{ pF}$ , See <a href="#">Figure 17</a>	25°C		$f = 10\text{ MHz}$	-73	dB
					$f = 1\text{ MHz}$	-95	
THD	Total harmonic distortion	$f = 20\text{ Hz to }20\text{ kHz}$ , $V_{COM} = 2\text{ V}_{P-P}$	25°C		$R_L = 32\ \Omega$	0.04%	
					$R_L = 600\ \Omega$	0.003%	
<b>DIGITAL CONTROL INPUTS (IN1, IN2)</b>							
$V_{IH}$	Input logic high		Full		1.4		V
$V_{IL}$	Input logic low		Full			0.5	
$I_{IN}$	Input leakage current	$V_I = 0\text{ or }V_{CC}$	25°C		0.5	1	nA
			Full		-20	20	
<b>SUPPLY</b>							

(1) The algebraic convention, whereby the most negative value is a minimum and the most positive value is a maximum.

(2) Parts are tested at 85°C and specified by design and correlation over the full temperature range.

(3) Typical values are at  $V_{CC} = 3\text{ V}$ ,  $T_A = 25^\circ\text{C}$ .

(4)  $\Delta R_{on} = R_{on(max)} - R_{on(min)}$

(5) Flatness is defined as the difference between the maximum and minimum value of  $r_{on}$  as measured over the specified analog signal ranges.

(6) Leakage parameters are 100% tested at the maximum-rated hot operating temperature and specified by correlation at  $T_A = 25^\circ\text{C}$ .

(7) OFF isolation =  $20_{\log}10 (V_{COM}/V_{NO})$ ,  $V_{COM}$  = output,  $V_{NO}$  = input to OFF switch

**Electrical Characteristics (3-V Supply)<sup>(1)(2)</sup> (continued)**
 $V_{CC} = 2.7\text{ V to }3.6\text{ V}$ ,  $T_A = -40\text{ to }85^\circ\text{C}$ ,  $V_{IH} = 1.4\text{ V}$ ,  $V_{IL} = 0.5\text{ V}$  (unless otherwise noted)

PARAMETER		TEST CONDITIONS	$T_A$	MIN	TYP <sup>(3)</sup>	MAX	UNIT
$V_{CC}$	Power-supply range			2.7		3.6	V
$I_{CC}$	Positive-supply current	$V_{CC} = 3.6\text{ V}$ , $V_{IN} = 0\text{ or }V_{CC}$	25°C			0.075	$\mu\text{A}$
			Full			0.75	

## 6.6 Electrical Characteristics (1.8-V Supply)<sup>(1) (2)</sup>

 $V_{CC} = 1.65\text{ V to }1.95\text{ V}$ ,  $T_A = -40\text{ to }85^\circ\text{C}$ ,  $V_{IH} = 1\text{ V}$ ,  $V_{IL} = 0.4\text{ V}$  (unless otherwise noted)

PARAMETER		TEST CONDITIONS	$T_A$	MIN	TYP <sup>(2)</sup>	MAX	UNIT
<b>ANALOG SWITCH</b>							
$V_{COM}, V_{NO}, V_{NC}$	Analog signal range			0		$V_+$	V
$R_{on}$	ON-state resistance	$V_{CC} = 1.8\text{ V}$ , $I_{COM} = -10\text{ mA}$ , $V_{NO}, V_{NC} = 0.9\text{ V}$	25 °C		1	1.5	Ω
			Full			2	
$\Delta R_{on}$	ON-state resistance match between channels <sup>(1)</sup>	$V_{CC} = 1.8\text{ V}$ , $I_{COM} = -10\text{ mA}$ , $V_{NO}, V_{NC} = 0.9\text{ V}$	25 °C		0.09	0.15	Ω
			Full			0.25	
$R_{on(Flat)}$	ON-state resistance flatness <sup>(3)</sup>	$V_{CC} = 1.8\text{ V}$ , $I_{COM} = -10\text{ mA}$ , $0 \leq V_{NO}, V_{NC} \leq V_{CC}$	25 °C		0.7	0.9	Ω
			Full			1.5	
$I_{NO(OFF)}$	NO OFF leakage current <sup>(4)</sup>	$V_{CC} = 1.95\text{ V}$ , $V_{COM} = 0.15\text{ V}$ , $1.65\text{ V}$ , $V_{NO} = 1.8\text{ V}$ , $0.15\text{ V}$	25 °C	-1	0.5	1	nA
			Full	-10		10	
$I_{COM(OFF)}$	COM OFF leakage current <sup>(4)</sup>	$V_{CC} = 1.95\text{ V}$ , $V_{COM} = 0.15\text{ V}$ , $1.65\text{ V}$ , $V_{NO} = 1.8\text{ V}$ , $0.15\text{ V}$	25 °C	-1	0.5	1	nA
			Full	-10		10	
$I_{COM(ON)}$	COM ON leakage current <sup>(4)</sup>	$V_{CC} = 1.95\text{ V}$ , $V_{COM} = 0.15\text{ V}$ , $1.65\text{ V}$ , $V_{NO} = 0.15\text{ V}$ , $1.65\text{ V}$ , or floating	25 °C	-1	0.01	1	nA
			Full	-3		3	
<b>DYNAMIC</b>							
$t_{ON}$	Turn-on time	$V_{NO}, V_{NC} = 1.5\text{ V}$ , $R_L = 50\ \Omega$ , $C_L = 35\text{ pF}$ , See <a href="#">Figure 14</a>	25 °C		6	18	ns
			Full			20	
$t_{OFF}$	Turn-off time	$V_{NO}, V_{NC} = 1.5\text{ V}$ , $R_L = 50\ \Omega$ , $C_L = 35\text{ pF}$ , See <a href="#">Figure 14</a>	25 °C		5	10	ns
			Full			12	
$Q_C$	Charge injection	$V_{GEN} = 0$ , $R_{GEN} = 0$ , $C_L = 1\text{ nF}$ , See <a href="#">Figure 15</a>	25 °C		3.2		pC
$C_{NO(OFF)}$	NO OFF capacitance	$f = 1\text{ MHz}$ , See <a href="#">Figure 16</a>	25 °C		23		pF
$C_{COM(OFF)}$	COM OFF capacitance	$f = 1\text{ MHz}$ , See <a href="#">Figure 16</a>	25 °C		20		
$C_{COM(ON)}$	COM ON capacitance	$f = 1\text{ MHz}$ , See <a href="#">Figure 16</a>	25 °C		43		
$BW$	Bandwidth	$R_L = 50\ \Omega$ , Switch ON	25 °C		123		MHz
$O_{ISO}$	OFF isolation <sup>(5)</sup>	$R_L = 50\ \Omega$ , $C_L = 5\text{ pF}$ , See <a href="#">Figure 17</a>	f = 10 MHz	25 °C		-61	dB
			f = 100 MHz			-36	
$X_{TALK}$	Crosstalk	$R_L = 50\ \Omega$ , $C_L = 5\text{ pF}$ , See <a href="#">Figure 17</a>	f = 10 MHz	25 °C		-95	dB
			f = 100 MHz			-73	
THD	Total harmonic distortion	f = 20 Hz to 20 kHz, $V_{COM} = 2\text{ V}_{P-P}$	$R_L = 32\ \Omega$	25 °C		0.14%	
			$R_L = 600\ \Omega$			0.013%	
<b>DIGITAL CONTROL INPUTS (IN1, IN2)</b>							
$V_{IH}$	Input logic high		Full	1			V
$V_{IL}$	Input logic low		Full			0.4	
$I_{IN}$	Input leakage current	$V_I = 0\text{ or }V_{CC}$	25 °C		0.1	5	nA
			Full		-10	10	
<b>SUPPLY</b>							
$V_{CC}$	Power-supply range			1.65		1.95	V
$I_{CC}$	Positive-supply current	$V_I = 0\text{ or }V_{CC}$	25 °C			0.05	μA
			Full			0.5	

(1)  $\Delta R_{on} = R_{on(max)} - R_{on(min)}$ 

(2) Typical values are at  $T_A = 25^\circ\text{C}$ .

(3) Flatness is defined as the difference between the maximum and minimum value of  $r_{on}$  as measured over the specified analog signal ranges.

(4) Leakage parameters are 100% tested at the maximum-rated hot operating temperature and specified by correlation at  $T_A = 25^\circ\text{C}$ .

(5) OFF isolation =  $20 \log_{10} (V_{COM}/V_{NO})$ ,  $V_{COM}$  = output,  $V_{NO}$  = input to OFF switch

### 6.7 Typical Characteristics

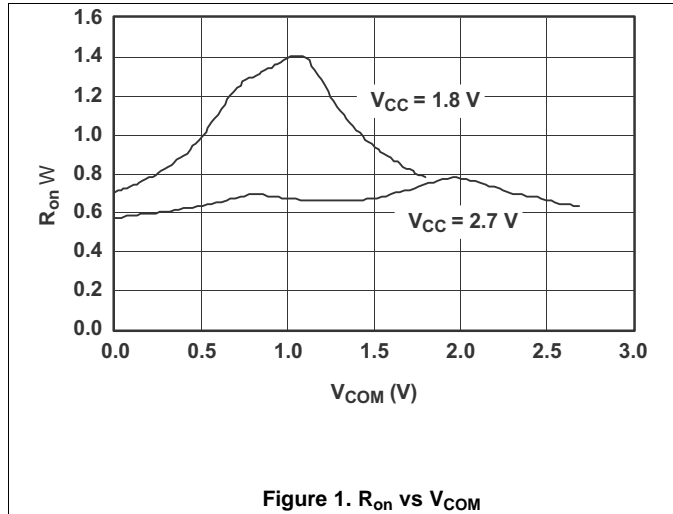

Figure 1.  $R_{on}$  vs  $V_{COM}$

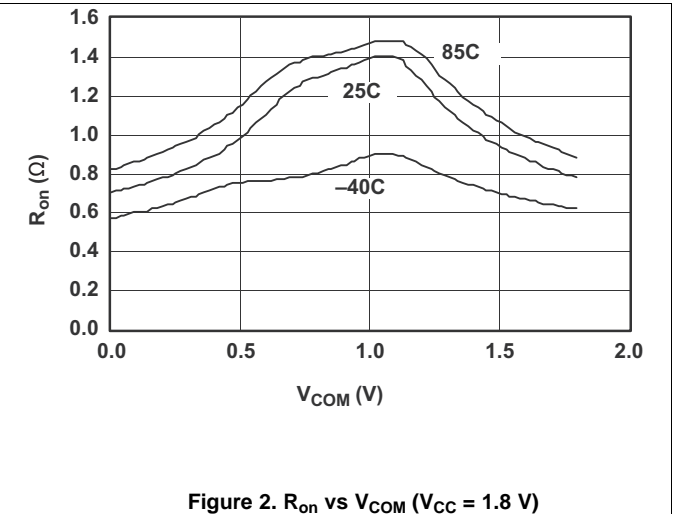

Figure 2.  $R_{on}$  vs  $V_{COM}$  ( $V_{CC} = 1.8\text{ V}$ )

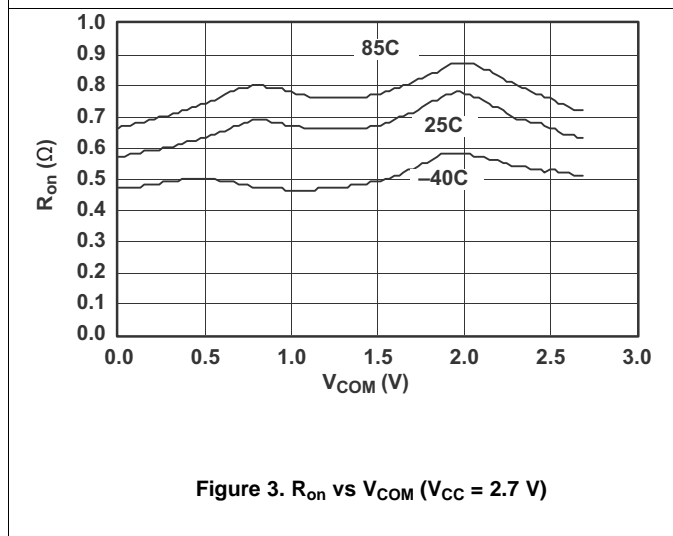

Figure 3.  $R_{on}$  vs  $V_{COM}$  ( $V_{CC} = 2.7\text{ V}$ )

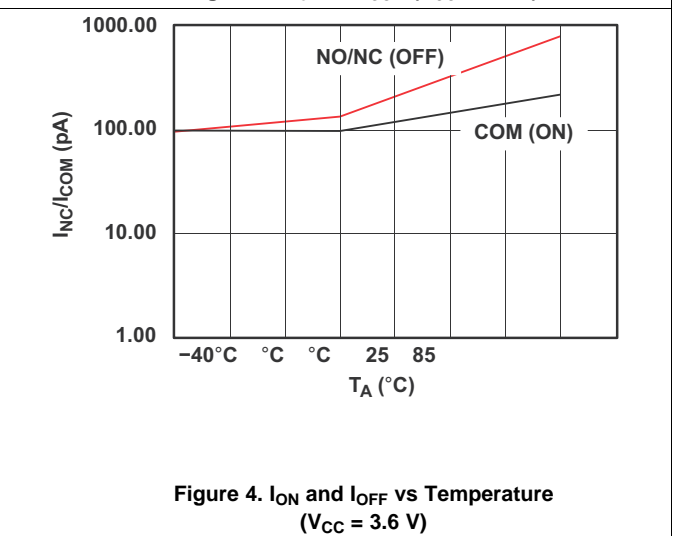

Figure 4.  $I_{ON}$  and  $I_{OFF}$  vs Temperature ( $V_{CC} = 3.6\text{ V}$ )

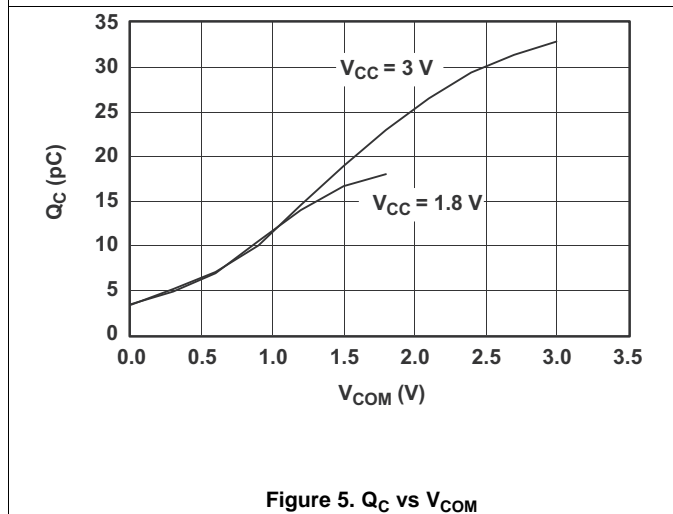

Figure 5.  $Q_C$  vs  $V_{COM}$

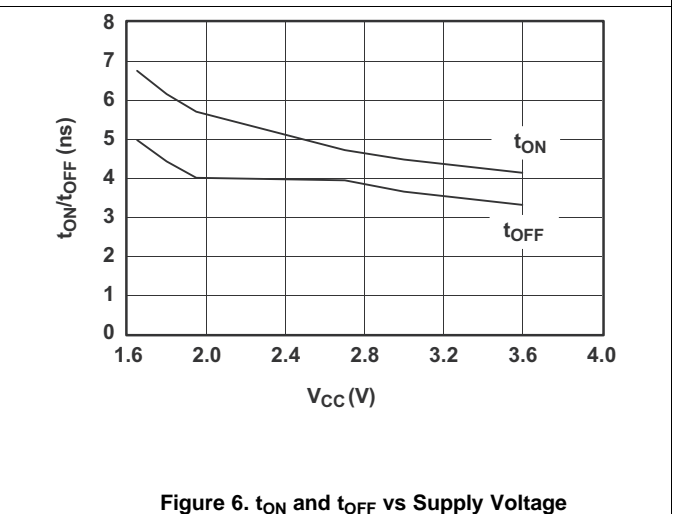
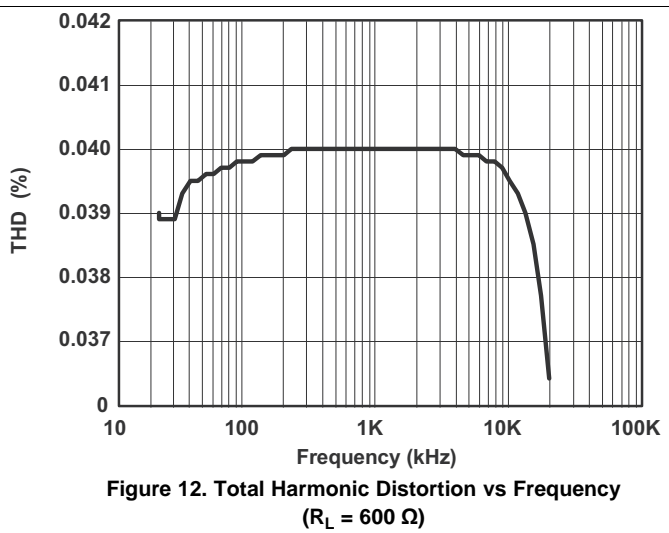
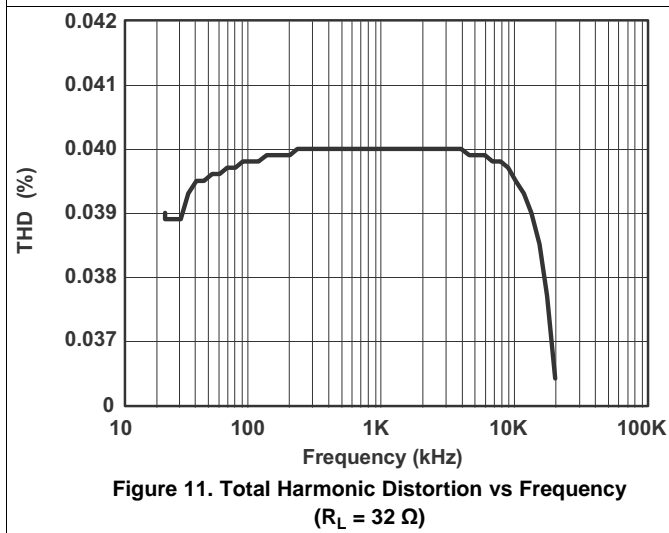
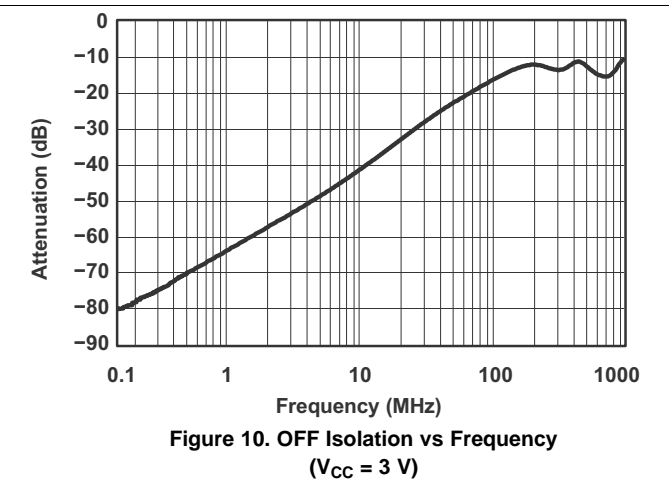
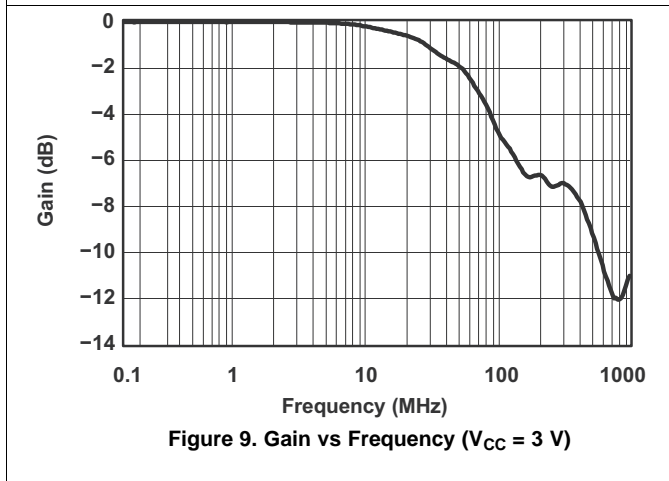
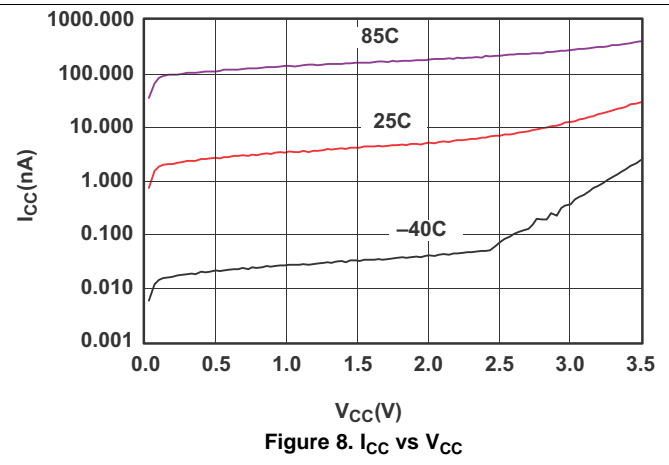
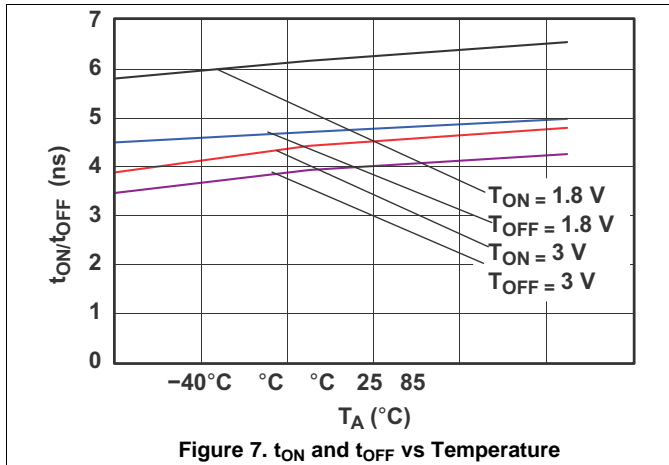
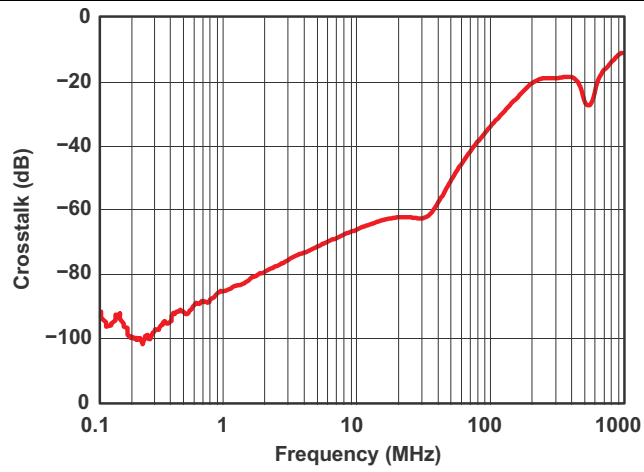

Figure 6.  $t_{ON}$  and  $t_{OFF}$  vs Supply Voltage

Typical Characteristics (continued)



**Typical Characteristics (continued)**



**Figure 13. Crosstalk vs Frequency**  
( $V_{CC} = 3\text{ V}$ )

## 7 Parameter Measurement Information

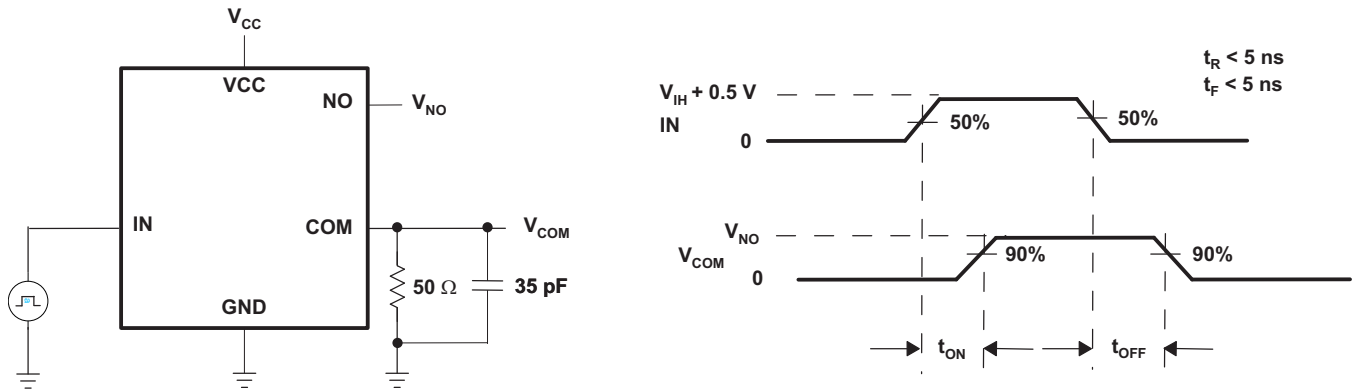

Figure 14. Switching Times

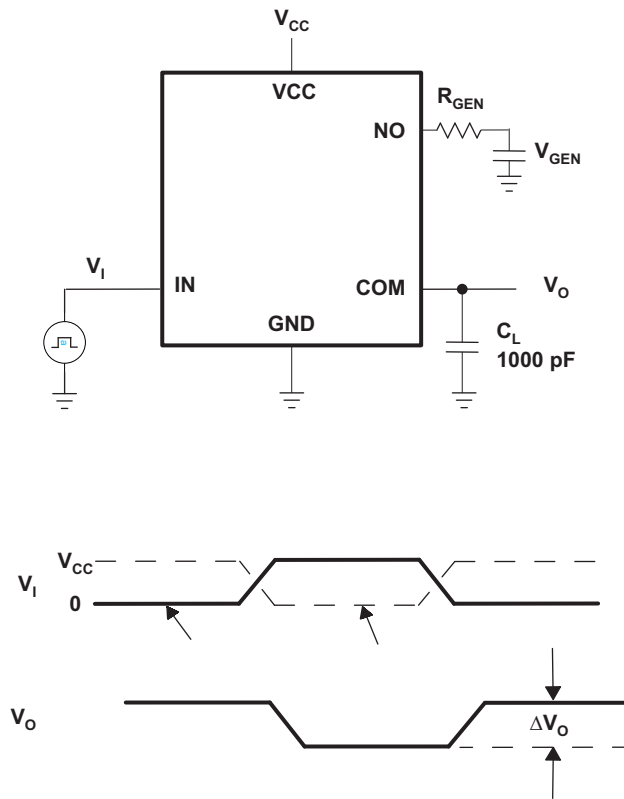

Figure 15. Charge Injection ( $Q_C$ )

Parameter Measurement Information (continued)

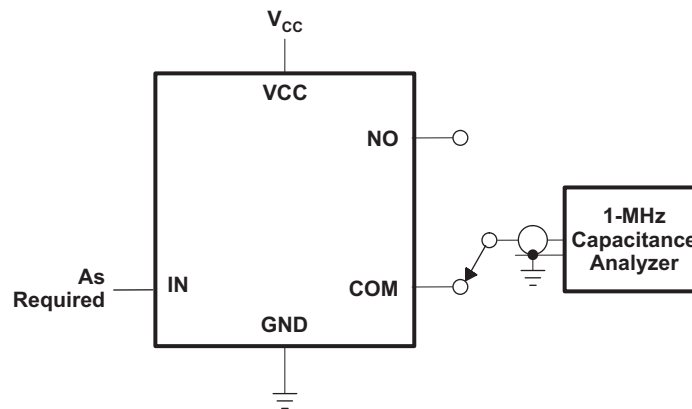
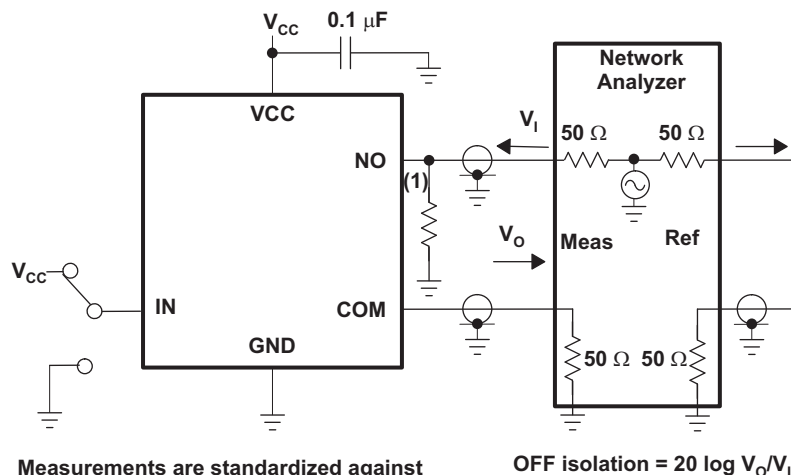

Figure 16. NO and COM Capacitance



Measurements are standardized against short at socket terminals. OFF isolation is measured between COM and OFF terminals on each switch. Bandwidth is measured between COM and ON terminals on each switch. Signal direction through switch is reversed; worst values are recorded.

$$\text{OFF isolation} = 20 \log V_o/V_i$$

<sup>(1)</sup> Add 50-Ω termination for OFF isolation

Figure 17. OFF Isolation, Bandwidth, and Crosstalk

Parameter Measurement Information (continued)

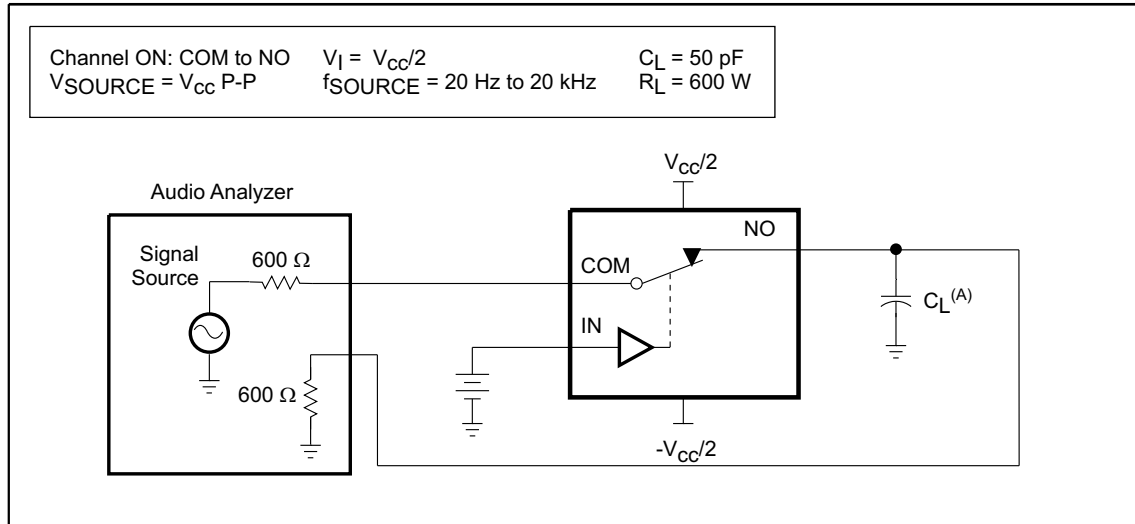

A.  $C_L$  includes probe and jig capacitance.

Figure 18. Total Harmonic Distortion (THD)

## 8 Detailed Description

### 8.1 Overview

The TS3A4741 and TS3A4742 are bi-directional, 2-channel single-pole/single-throw (SPST) analog switches with low ON-state resistance ( $R_{on}$ ), low-voltage, that operate from a single 1.6-V to 3.6-V supply. These devices have fast switching speeds, handle rail-to-rail analog signals, and consume very low quiescent power.

The digital logic input is 1.8-V CMOS compatible when using a single 3-V supply.

The TS3A4741 has two normally open (NO) switches, and the TS3A4742 has two normally closed (NC) switches.

### 8.2 Functional Block Diagram

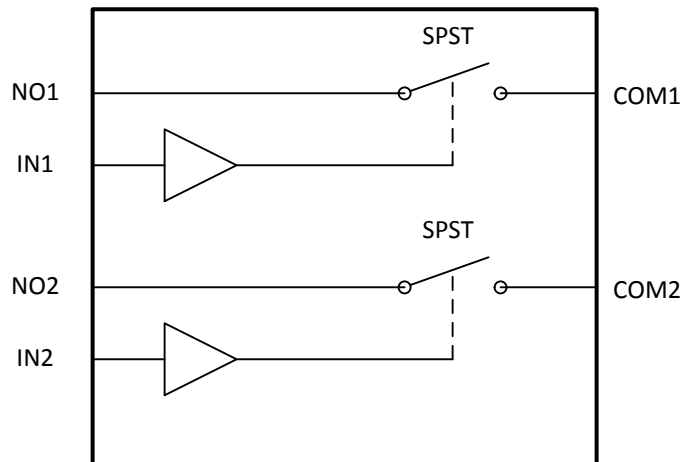

### 8.3 Feature Description

The TS3A4741 and TS3A4742 has a low on resistance and high current handling capability up to 100 mA continuous current so it can be used for power sequencing and routing with minimal losses. The switch is also bi-directional with fast switching times in the 10 ns range which allows data acquisition and communication between multiple devices.

With a 3-V supply these devices are compatible with standard 1.8-V CMOS logic.

### 8.4 Device Functional Modes

**Table 1. Function Table**

IN	NO to COM, COM to NO (TS3A4741)	NC to COM, COM to NC (TS3A4742)
L	OFF	ON
H	ON	OFF

## 9 Application and Implementation

### NOTE

Information in the following applications sections is not part of the TI component specification, and TI does not warrant its accuracy or completeness. TI's customers are responsible for determining suitability of components for their purposes. Customers should validate and test their design implementation to confirm system functionality.

### 9.1 Application Information

Analog signals that range over the entire supply voltage ( $V_{CC}$  to GND) of the TS3A4741 and TS3A4742 can be passed with very little change in  $R_{on}$  (see [Typical Characteristics](#)). The switches are bidirectional, so the NO, NC, and COM pins can be used as either inputs or outputs.

### 9.2 Typical Application

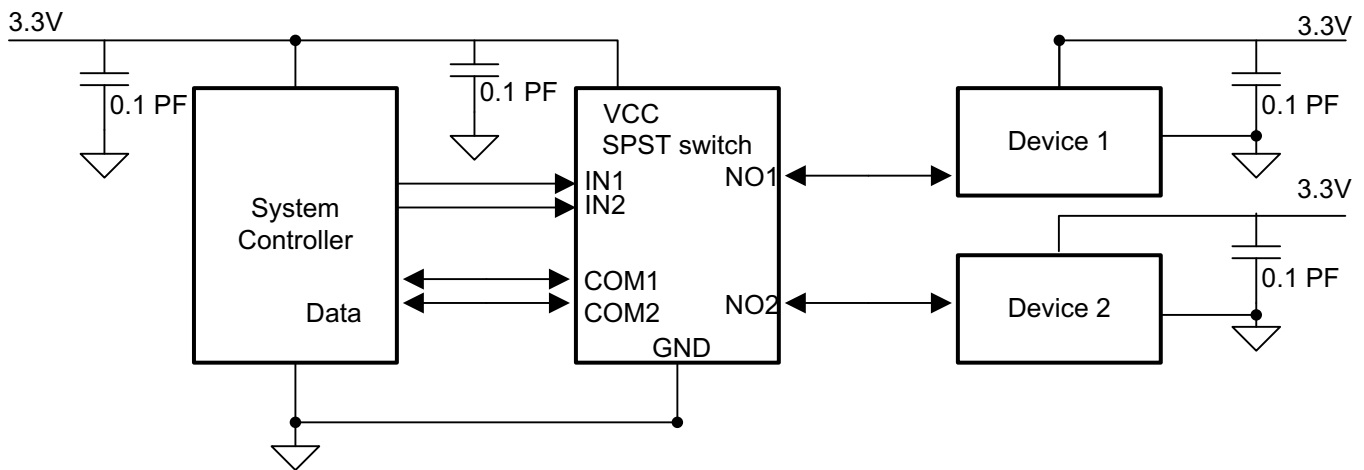

Figure 19. Typical Application Schematic

#### 9.2.1 Design Requirements

Ensure that all of the signals passing through the switch are within the specified ranges to ensure proper performance.

#### 9.2.2 Detailed Design Procedure

The TS3A474x can be properly operated without any external components. However, TI recommends that unused pins should be connected to ground through a 50- $\Omega$  resistor to prevent signal reflections back into the device. TI also recommends that the digital control pins ( $IN_x$ ) be pulled up to  $V_{CC}$  or down to GND to avoid undesired switch positions that could result from the floating pin.

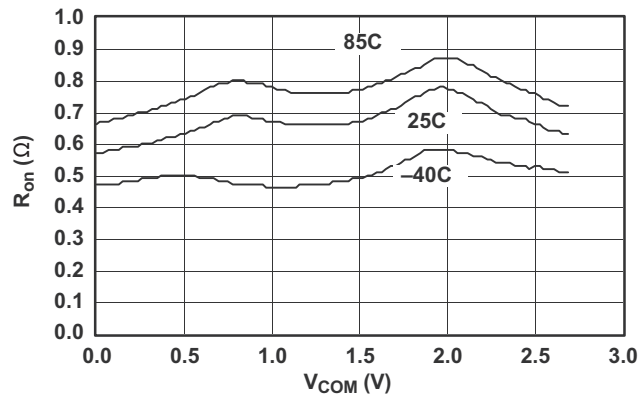
**Typical Application (continued)**
**9.2.3 Application Curve**

**Figure 20.  $R_{on}$  vs  $V_{COM}$  ( $V_{CC} = 2.7$  V)**

## 10 Power Supply Recommendations

Proper power-supply sequencing is recommended for all CMOS devices. Do not exceed the absolute maximum ratings, because stresses beyond the listed ratings can cause permanent damage to the device. Always sequence VCC on first, followed by NO, NC, or COM.

Although it is not required, power-supply bypassing improves noise margin and prevents switching noise propagation from the VCC supply to other components. A 0.1- $\mu$ F capacitor, connected from VCC to GND, is adequate for most applications.

## 11 Layout

### 11.1 Layout Guidelines

High-speed switches require proper layout and design procedures for optimum performance. Reduce stray inductance and capacitance by keeping traces short and wide. Ensure that bypass capacitors are as close to the device as possible. Use large ground planes where possible. Use large ground planes where possible.

### 11.2 Layout Example

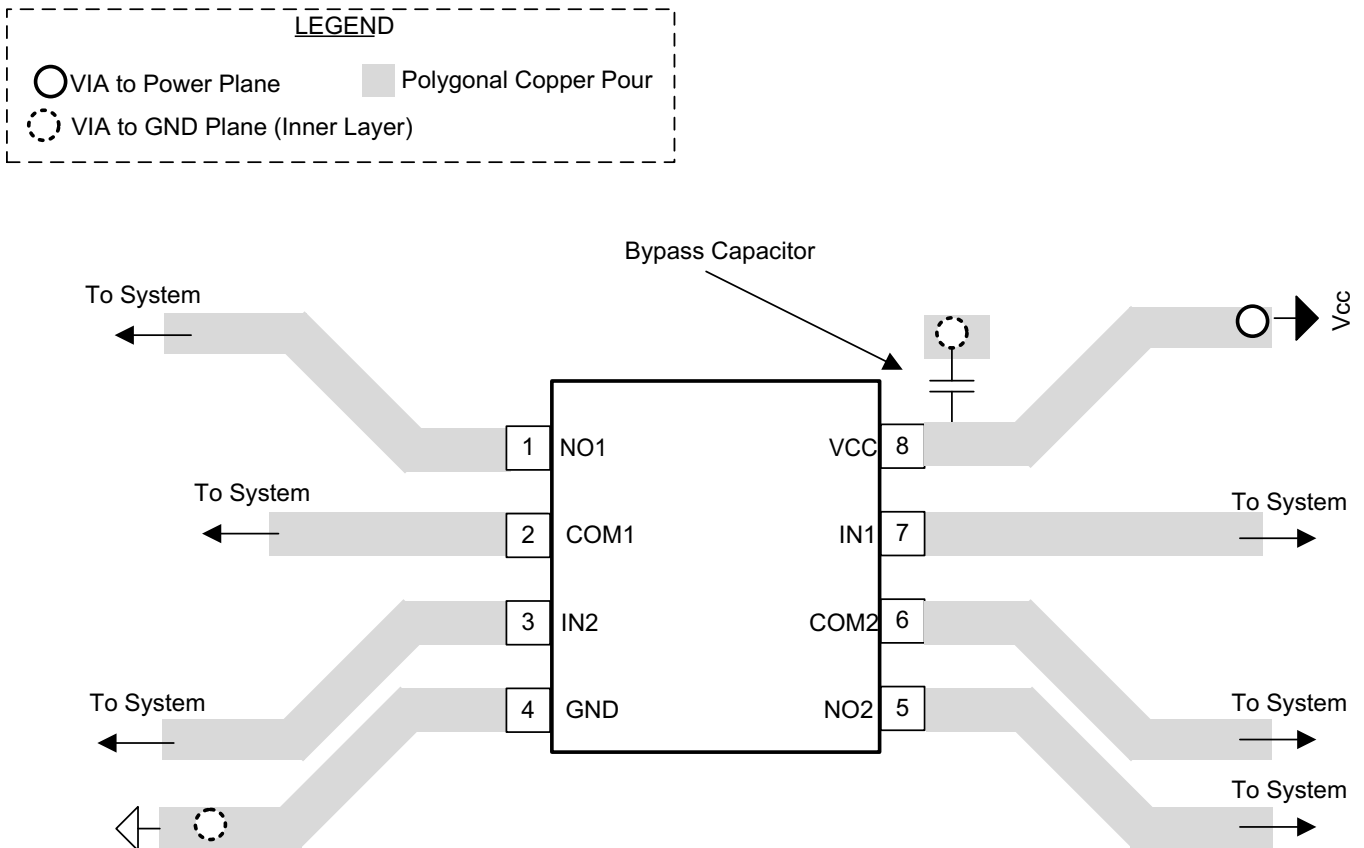

Figure 21. PCB Layout Example

## 12 Device and Documentation Support

### 12.1 Related Links

The table below lists quick access links. Categories include technical documents, support and community resources, tools and software, and quick access to sample or buy.

**Table 2. Related Links**

PARTS	PRODUCT FOLDER	SAMPLE & BUY	TECHNICAL DOCUMENTS	TOOLS & SOFTWARE	SUPPORT & COMMUNITY
TS3A4741	<a href="#">Click here</a>	<a href="#">Click here</a>	<a href="#">Click here</a>	<a href="#">Click here</a>	<a href="#">Click here</a>
TS3A4742	<a href="#">Click here</a>	<a href="#">Click here</a>	<a href="#">Click here</a>	<a href="#">Click here</a>	<a href="#">Click here</a>

### 12.2 Trademarks

All trademarks are the property of their respective owners.

### 12.3 Electrostatic Discharge Caution



These devices have limited built-in ESD protection. The leads should be shorted together or the device placed in conductive foam during storage or handling to prevent electrostatic damage to the MOS gates.

### 12.4 Glossary

[SLYZ022](#) — *TI Glossary*.

This glossary lists and explains terms, acronyms, and definitions.

## 13 Mechanical, Packaging, and Orderable Information

The following pages include mechanical, packaging, and orderable information. This information is the most current data available for the designated devices. This data is subject to change without notice and revision of this document. For browser-based versions of this data sheet, refer to the left-hand navigation.

**PACKAGING INFORMATION**

Orderable Device	Status (1)	Package Type	Package Drawing	Pins	Package Qty	Eco Plan (2)	Lead/Ball Finish (6)	MSL Peak Temp (3)	Op Temp (°C)	Device Marking (4/5)	Samples
TS3A4741DCNR	ACTIVE	SOT-23	DCN	8	3000	Green (RoHS & no Sb/Br)	CU NIPDAU	Level-1-260C-UNLIM	-40 to 85	(8BLO ~ 8BLR)	<a href="#">Samples</a>
TS3A4741DGKR	ACTIVE	VSSOP	DGK	8	2500	Green (RoHS & no Sb/Br)	CU NIPDAU	Level-1-260C-UNLIM	-40 to 85	JYR	<a href="#">Samples</a>
TS3A4742DCNR	ACTIVE	SOT-23	DCN	8	3000	Green (RoHS & no Sb/Br)	CU NIPDAU	Level-1-260C-UNLIM	-40 to 85	8BPR	<a href="#">Samples</a>
TS3A4742DGKR	ACTIVE	VSSOP	DGK	8	2500	Green (RoHS & no Sb/Br)	CU NIPDAU	Level-1-260C-UNLIM	-40 to 85	L7R	<a href="#">Samples</a>

(1) The marketing status values are defined as follows:

**ACTIVE:** Product device recommended for new designs.

**LIFEBUY:** TI has announced that the device will be discontinued, and a lifetime-buy period is in effect.

**NRND:** Not recommended for new designs. Device is in production to support existing customers, but TI does not recommend using this part in a new design.

**PREVIEW:** Device has been announced but is not in production. Samples may or may not be available.

**OBSELETE:** TI has discontinued the production of the device.

(2) Eco Plan - The planned eco-friendly classification: Pb-Free (RoHS), Pb-Free (RoHS Exempt), or Green (RoHS & no Sb/Br) - please check <http://www.ti.com/productcontent> for the latest availability information and additional product content details.

**TBD:** The Pb-Free/Green conversion plan has not been defined.

**Pb-Free (RoHS):** TI's terms "Lead-Free" or "Pb-Free" mean semiconductor products that are compatible with the current RoHS requirements for all 6 substances, including the requirement that lead not exceed 0.1% by weight in homogeneous materials. Where designed to be soldered at high temperatures, TI Pb-Free products are suitable for use in specified lead-free processes.

**Pb-Free (RoHS Exempt):** This component has a RoHS exemption for either 1) lead-based flip-chip solder bumps used between the die and package, or 2) lead-based die adhesive used between the die and leadframe. The component is otherwise considered Pb-Free (RoHS compatible) as defined above.

**Green (RoHS & no Sb/Br):** TI defines "Green" to mean Pb-Free (RoHS compatible), and free of Bromine (Br) and Antimony (Sb) based flame retardants (Br or Sb do not exceed 0.1% by weight in homogeneous material)

(3) MSL, Peak Temp. - The Moisture Sensitivity Level rating according to the JEDEC industry standard classifications, and peak solder temperature.

(4) There may be additional marking, which relates to the logo, the lot trace code information, or the environmental category on the device.

(5) Multiple Device Markings will be inside parentheses. Only one Device Marking contained in parentheses and separated by a "~" will appear on a device. If a line is indented then it is a continuation of the previous line and the two combined represent the entire Device Marking for that device.

(6) Lead/Ball Finish - Orderable Devices may have multiple material finish options. Finish options are separated by a vertical ruled line. Lead/Ball Finish values may wrap to two lines if the finish value exceeds the maximum column width.

**Important Information and Disclaimer:** The information provided on this page represents TI's knowledge and belief as of the date that it is provided. TI bases its knowledge and belief on information provided by third parties, and makes no representation or warranty as to the accuracy of such information. Efforts are underway to better integrate information from third parties. TI has taken and continues to take reasonable steps to provide representative and accurate information but may not have conducted destructive testing or chemical analysis on incoming materials and chemicals. TI and TI suppliers consider certain information to be proprietary, and thus CAS numbers and other limited information may not be available for release.

In no event shall TI's liability arising out of such information exceed the total purchase price of the TI part(s) at issue in this document sold by TI to Customer on an annual basis.

**TAPE AND REEL INFORMATION**

**QUADRANT ASSIGNMENTS FOR PIN 1 ORIENTATION IN TAPE**

\*All dimensions are nominal

Device	Package Type	Package Drawing	Pins	SPQ	Reel Diameter (mm)	Reel Width W1 (mm)	A0 (mm)	B0 (mm)	K0 (mm)	P1 (mm)	W (mm)	Pin1 Quadrant
TS3A4741DCNR	SOT-23	DCN	8	3000	180.0	8.4	3.23	3.17	1.37	4.0	8.0	Q3
TS3A4741DGKR	VSSOP	DGK	8	2500	330.0	12.4	5.3	3.4	1.4	8.0	12.0	Q1
TS3A4742DCNR	SOT-23	DCN	8	3000	180.0	8.4	3.23	3.17	1.37	4.0	8.0	Q3
TS3A4742DGKR	VSSOP	DGK	8	2500	330.0	12.4	5.3	3.4	1.4	8.0	12.0	Q1

**TAPE AND REEL BOX DIMENSIONS**



\*All dimensions are nominal

Device	Package Type	Package Drawing	Pins	SPQ	Length (mm)	Width (mm)	Height (mm)
TS3A4741DCNR	SOT-23	DCN	8	3000	202.0	201.0	28.0
TS3A4741DGKR	VSSOP	DGK	8	2500	358.0	335.0	35.0
TS3A4742DCNR	SOT-23	DCN	8	3000	202.0	201.0	28.0
TS3A4742DGKR	VSSOP	DGK	8	2500	358.0	335.0	35.0

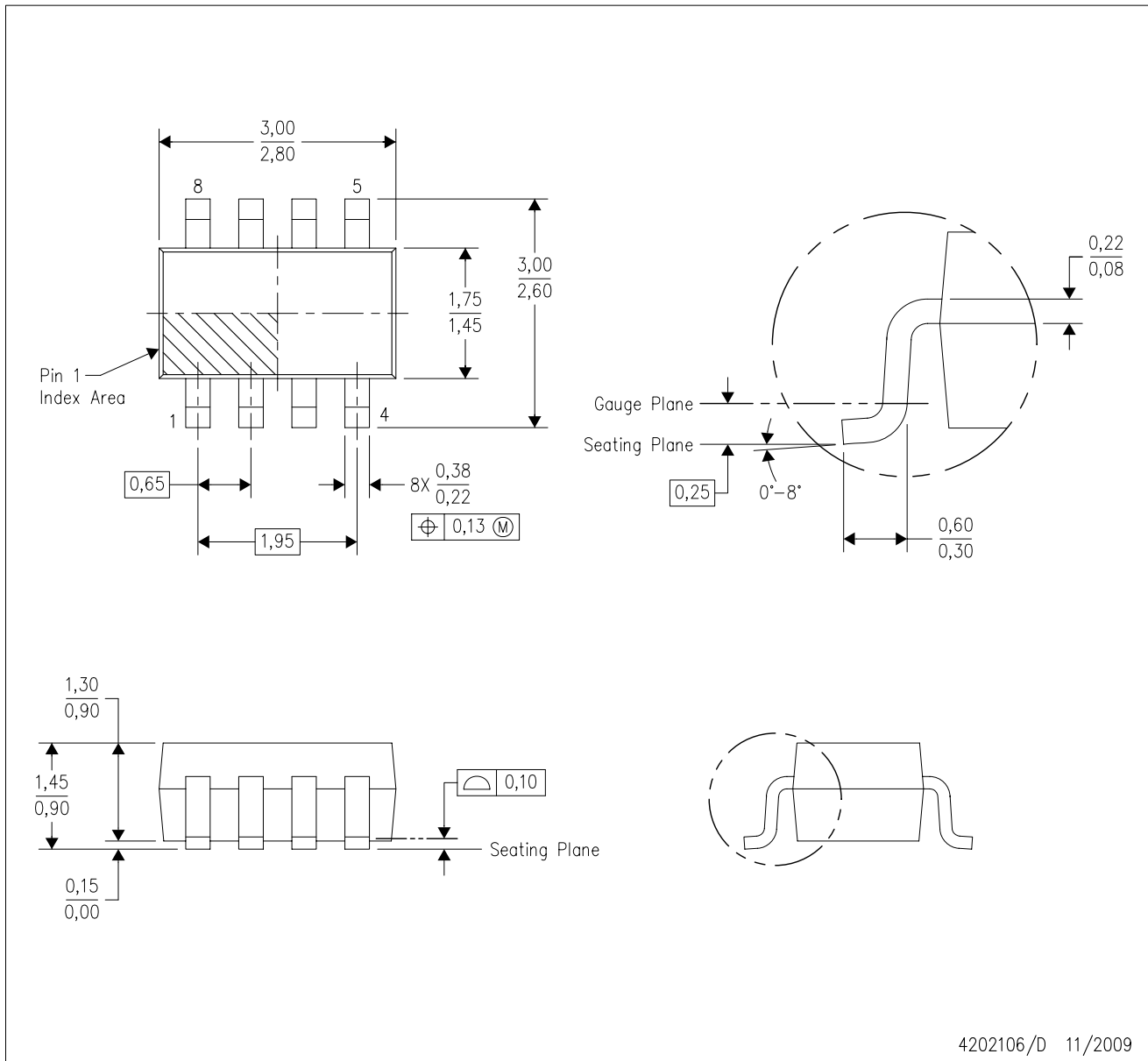

DCN (R-PDSO-G8)

PLASTIC SMALL-OUTLINE PACKAGE (DIE DOWN)



- NOTES:
- A. All linear dimensions are in millimeters.
  - B. This drawing is subject to change without notice.
  - C. Package outline exclusive of metal burr & dambar protrusion/intrusion.
  - D. Package outline inclusive of solder plating.
  - E. A visual index feature must be located within the Pin 1 index area.
  - F. Falls within JEDEC MO-178 Variation BA.
  - G. Body dimensions do not include flash or protrusion. Mold flash and protrusion shall not exceed 0.25 per side.

DCN (R-PDSO-G8)

PLASTIC SMALL-OUTLINE PACKAGE (DIE DOWN)



- NOTES:
- A. All linear dimensions are in millimeters.
  - B. This drawing is subject to change without notice.
  - C. Publication IPC-7351 is recommended for alternate designs.
  - D. Laser cutting apertures with trapezoidal walls and also rounding corners will offer better paste release. Customers should contact their board assembly site for stencil design recommendations. Refer to IPC-7525.
  - E. Customers should contact their board fabrication site for solder mask tolerances between and around signal pads.

## IMPORTANT NOTICE

Texas Instruments Incorporated and its subsidiaries (TI) reserve the right to make corrections, enhancements, improvements and other changes to its semiconductor products and services per JESD46, latest issue, and to discontinue any product or service per JESD48, latest issue. Buyers should obtain the latest relevant information before placing orders and should verify that such information is current and complete. All semiconductor products (also referred to herein as "components") are sold subject to TI's terms and conditions of sale supplied at the time of order acknowledgment.

TI warrants performance of its components to the specifications applicable at the time of sale, in accordance with the warranty in TI's terms and conditions of sale of semiconductor products. Testing and other quality control techniques are used to the extent TI deems necessary to support this warranty. Except where mandated by applicable law, testing of all parameters of each component is not necessarily performed.

TI assumes no liability for applications assistance or the design of Buyers' products. Buyers are responsible for their products and applications using TI components. To minimize the risks associated with Buyers' products and applications, Buyers should provide adequate design and operating safeguards.

TI does not warrant or represent that any license, either express or implied, is granted under any patent right, copyright, mask work right, or other intellectual property right relating to any combination, machine, or process in which TI components or services are used. Information published by TI regarding third-party products or services does not constitute a license to use such products or services or a warranty or endorsement thereof. Use of such information may require a license from a third party under the patents or other intellectual property of the third party, or a license from TI under the patents or other intellectual property of TI.

Reproduction of significant portions of TI information in TI data books or data sheets is permissible only if reproduction is without alteration and is accompanied by all associated warranties, conditions, limitations, and notices. TI is not responsible or liable for such altered documentation. Information of third parties may be subject to additional restrictions.

Resale of TI components or services with statements different from or beyond the parameters stated by TI for that component or service voids all express and any implied warranties for the associated TI component or service and is an unfair and deceptive business practice. TI is not responsible or liable for any such statements.

Buyer acknowledges and agrees that it is solely responsible for compliance with all legal, regulatory and safety-related requirements concerning its products, and any use of TI components in its applications, notwithstanding any applications-related information or support that may be provided by TI. Buyer represents and agrees that it has all the necessary expertise to create and implement safeguards which anticipate dangerous consequences of failures, monitor failures and their consequences, lessen the likelihood of failures that might cause harm and take appropriate remedial actions. Buyer will fully indemnify TI and its representatives against any damages arising out of the use of any TI components in safety-critical applications.

In some cases, TI components may be promoted specifically to facilitate safety-related applications. With such components, TI's goal is to help enable customers to design and create their own end-product solutions that meet applicable functional safety standards and requirements. Nonetheless, such components are subject to these terms.

No TI components are authorized for use in FDA Class III (or similar life-critical medical equipment) unless authorized officers of the parties have executed a special agreement specifically governing such use.

Only those TI components which TI has specifically designated as military grade or "enhanced plastic" are designed and intended for use in military/aerospace applications or environments. Buyer acknowledges and agrees that any military or aerospace use of TI components which have **not** been so designated is solely at the Buyer's risk, and that Buyer is solely responsible for compliance with all legal and regulatory requirements in connection with such use.

TI has specifically designated certain components as meeting ISO/TS16949 requirements, mainly for automotive use. In any case of use of non-designated products, TI will not be responsible for any failure to meet ISO/TS16949.

### Products

Audio	<a href="http://www.ti.com/audio">www.ti.com/audio</a>
Amplifiers	<a href="http://amplifier.ti.com">amplifier.ti.com</a>
Data Converters	<a href="http://dataconverter.ti.com">dataconverter.ti.com</a>
DLP® Products	<a href="http://www.dlp.com">www.dlp.com</a>
DSP	<a href="http://dsp.ti.com">dsp.ti.com</a>
Clocks and Timers	<a href="http://www.ti.com/clocks">www.ti.com/clocks</a>
Interface	<a href="http://interface.ti.com">interface.ti.com</a>
Logic	<a href="http://logic.ti.com">logic.ti.com</a>
Power Mgmt	<a href="http://power.ti.com">power.ti.com</a>
Microcontrollers	<a href="http://microcontroller.ti.com">microcontroller.ti.com</a>
RFID	<a href="http://www.ti-rfid.com">www.ti-rfid.com</a>
OMAP Applications Processors	<a href="http://www.ti.com/omap">www.ti.com/omap</a>
Wireless Connectivity	<a href="http://www.ti.com/wirelessconnectivity">www.ti.com/wirelessconnectivity</a>

### Applications

Automotive and Transportation	<a href="http://www.ti.com/automotive">www.ti.com/automotive</a>
Communications and Telecom	<a href="http://www.ti.com/communications">www.ti.com/communications</a>
Computers and Peripherals	<a href="http://www.ti.com/computers">www.ti.com/computers</a>
Consumer Electronics	<a href="http://www.ti.com/consumer-apps">www.ti.com/consumer-apps</a>
Energy and Lighting	<a href="http://www.ti.com/energy">www.ti.com/energy</a>
Industrial	<a href="http://www.ti.com/industrial">www.ti.com/industrial</a>
Medical	<a href="http://www.ti.com/medical">www.ti.com/medical</a>
Security	<a href="http://www.ti.com/security">www.ti.com/security</a>
Space, Avionics and Defense	<a href="http://www.ti.com/space-avionics-defense">www.ti.com/space-avionics-defense</a>
Video and Imaging	<a href="http://www.ti.com/video">www.ti.com/video</a>

### TI E2E Community

[e2e.ti.com](http://e2e.ti.com)